

VFD CABLES

100% EMI CONTAINMENT

HIGHLY FLEXIBLE & DURABLE



AmerCable

ENERGY GROUP

VFD CABLES

Index



- 100% EMI Containment
- Highly Flexible & Durable
- Four Constructions
- Shortest Lead Times
- Best On-Time Delivery Rate

*Visit www.AmerCable.com for today's on-time delivery rate

Standard VFD Power Cable	2 - 3
Low Smoke Halogen-Free VFD Power Cable	4 - 5
CIR® VFD Power Cable	6 - 7
<hr style="border: 1px solid red;"/>	
RATED TC-ER-HL	
MMV-VFD Power Cable	8 - 9
VFD Cable Selection Guide	10 - 11

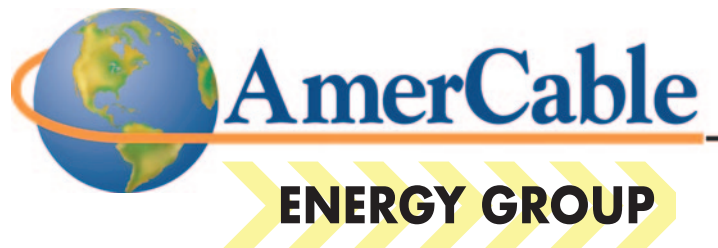

AmerCable believes the information presented throughout this catalog to be reliable and current. All information is subject to change without notice. The information listed is approximate, and is presented only as a guide for product selection. We make no claims or warranties for the suitability of any product for any particular application.

Gexol® is a registered trademark of AmerCable Incorporated. Registered in the U.S. Patent and Trademark Office.

© 202 AmerCable Incorporated

AmerCable VFD Cables are specially engineered to provide 100% containment of EMI emissions and provide longer cable life in VFD applications.

AmerCable VFD cables feature symmetrical insulated ground conductors that reduce induced voltage imbalances and carry common mode noise back to the drive.

AmerCable's high strand count conductors and braid shield design is much more flexible, easier to install and more resistant to vibration than Type MC cable.

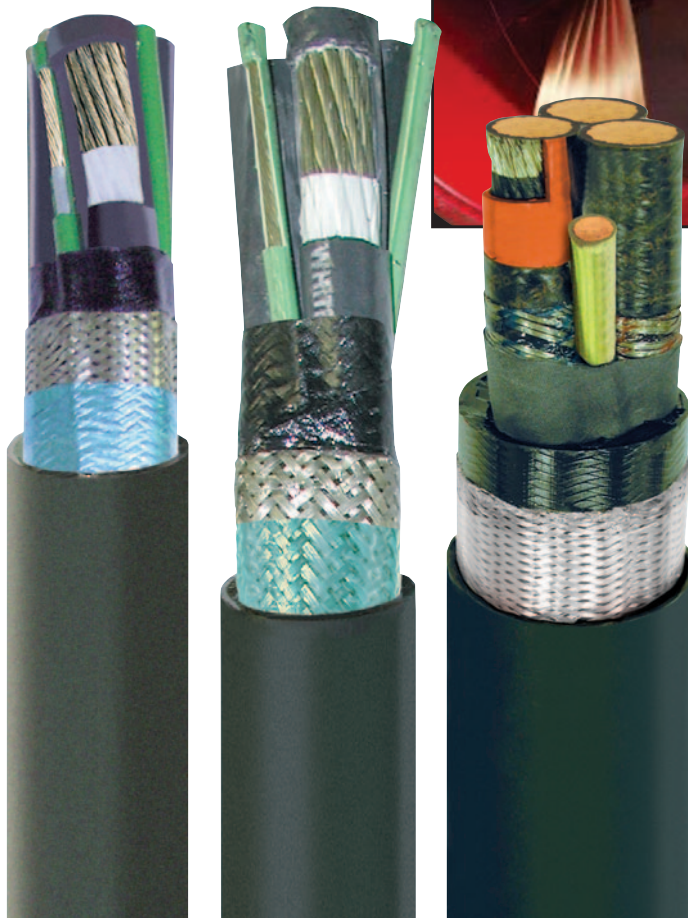
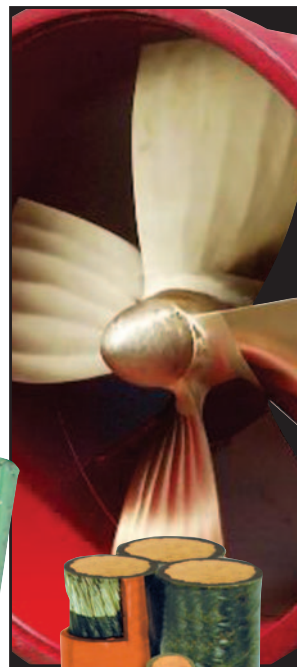

Hawke Gland Types

Hawke Gland Types	Unarmored	Armored & Sheathed
Industrial & Safe Area (IP68)	121	153-X
Increased Safety "EExe"	501/421	501/453/U
Explosion Proof	710 Class I, Div. 2 Class I, Zone 2	753 Class I, Div. 1 Class I, Zone 1 & 2
Flameproof "EExd"	501/421 Zone 1 & 2	501/453/U (2 liter or < enclosures) ICG 653/U (2 liter or > enclosures) Zone 1 & 2

Standard VFD Power Cable

Gexol® Insulated

Three Conductor • 2kV • Rated 110°C

Power Conductors (x3)

Soft annealed flexible stranded finned copper per IEEE 1580 Table 11.

Insulation (2kV)

Gexol® cross-linked flame retardant polyolefin, meeting the requirements for Type P of IEEE 1580 and Type X110 of UL 1309/CSA 245.

Color: Gray with printed phase I.D. (Black-White-Red)

Jacket

A black, arctic grade, flame retardant, oil, abrasion, chemical and sunlight resistant thermosetting compound meeting UL 1309/CSA 245 and IEEE 1580.

Armor (Optional)

Tinned copper basket weave wire armor per IEEE 1580 and UL 1309/CSA 245.



Ground Conductors (x3)

Soft annealed flexible stranded tinned copper per IEEE 1580 Table 11. Gexol® insulated and sized per UL 1277. Color: Green

Shield

Overall tinned copper braid plus aluminum/polyester tape providing 100% coverage.

Sheath (Optional)

A black, arctic grade, flame retardant, oil, abrasion, chemical and sunlight resistant thermosetting compound meeting UL 1309/CSA 245 and IEEE 1580.

Note: For armored versions the braid is placed between the inner jacket and outer sheath where it serves as both the EMI shield and armor.

APPLICATION

A flexible, braid and foil shielded, 2kV power cable specifically engineered for use in variable frequency AC motor drive (VFD) applications.

FEATURES

- Specially engineered cable design produces a longer cable life in VFD applications.
- Overall braid plus foil shield is engineered with 100% coverage and a surface transfer impedance <50 milliohms at 10MHz to contain EMI.
- Symmetrical insulated ground conductors reduce induced voltage imbalances and carry common mode noise back to the drive.
- High strand count conductors and braid shield design is much more flexible, easier to install and more resistant to vibration than Type MC cable.
- Gexol's lower dielectric constant (standard XLPEs, EPRs and other Type P insulation materials have higher dielectric constants) reduces reflected wave peak voltage magnitudes. This allows for longer output cable distances and minimizes the effect of high frequency noise induced into the plant ground system.
- 2kV insulation thickness is used to resist the potential 2-3x reflected voltages experienced in 600V VFD applications.
- Dual certified IEEE 1580 Type P and UL 1309/CSA 245 Type X110.
- Highest ampacity ratings: ABS 100°C, DNV 95°C, LRS 95°C, Transport Canada 95°C.
- Severe cold durability: exceeds CSA cold bend/cold impact (-40°C/-35°C).
- Flame retardant: IEC 332-3 Category A and IEEE 1202.
- Suitable for use in Class I, Division 1 and Zone 1 environments (armored and sheathed).
- Optional braid armor of bronze, aluminum or tinned copper.

Ratings & Approvals

- 110°C Temperature Rating
- American Bureau of Shipping (ABS)
- Transport Canada
- Det Norske Veritas (DNV)
- Lloyd's Register of Shipping (LRS)
- NVE: 95/1696, FAL
- UL Listed as Marine Shipboard Cable: (E111461)
- Unarmored Cable is UL Listed as Type TC (E123629)
- United States Coast Guard: November 2, 1987 / 9304

Other certifications pending

Unarmored					Armored & Sheathed (TS)			DC Resist. at 25°C Ohms/ 1000 Ft.	AC Resist. at 90°C, 60 Hz Ohms/ 1000 Ft.	Inductive Reactance Ohms/ 1000 Ft.	Voltage Drop at 90°C Volts/Amp/ 1000 Ft.	Grounding Conductor** Size (AWG)	Ampacity			
Size AWG/ kcmil	mm ²	Part No. 37-102	Nominal Diameter Inches*	Weight Lbs./ 1000 Ft.	Part No. 37-102	Nominal Diameter Inches*	Weight Lbs./ 1000 Ft.						110°C	100°C	90°C	75°C
14	2.1	-508VFD	0.630	194	-508TSVFD	0.772	356	2.907	3.859	0.040	5.383	18	27	25	24	20
12	3.3	-516VFD	0.675	224	-516TSVFD	0.795	401	1.826	2.424	0.038	3.394	18	33	31	29	24
10	5.2	-308VFD	0.750	308	-308TSVFD	0.918	518	1.153	1.530	0.036	2.155	14	44	41	38	32
8	7.6	-309VFD	0.815	463	-309TSVFD	1.000	734	0.708	0.940	0.037	1.339	14	56	52	48	41
6	12.5	-310VFD	0.910	570	-310TSVFD	1.110	865	0.445	0.590	0.033	0.852	12	75	70	65	54
4	21	-312VFD	1.100	925	-312TSVFD	1.262	1138	0.300	0.399	0.031	0.584	12	99	92	83	70
2	34	-314VFD	1.235	1421	-314TSVFD	1.392	1512	0.184	0.244	0.029	0.368	10	131	122	111	93
1	43	-315VFD	1.340	1517	-315TSVFD	1.509	1851	0.147	0.195	0.029	0.301	10	153	143	131	110
1/0	54	-316VFD	1.450	1803	-316TSVFD	1.615	2136	0.117	0.156	0.029	0.246	10	176	164	150	126
2/0	70	-317VFD	1.580	2120	-317TSVFD	1.792	2660	0.093	0.125	0.028	0.202	10	201	188	173	145
3/0	86	-318VFD	1.750	2827	-318TSVFD	1.959	3269	0.074	0.100	0.028	0.167	8	234	218	200	168
4/0	109	-319VFD	1.900	3416	-319TSVFD	2.101	3864	0.058	0.080	0.027	0.139	8	270	252	232	194
262	132	-320VFD	2.050	4210	-320TSVFD	2.258	4661	0.048	0.067	0.027	0.120	6	315	294	273	228
313	159	-321VFD	2.130	5105	-321TSVFD	2.353	5325	0.040	0.056	0.026	0.105	6	344	321	298	249
373	189	-322VFD	2.275	5521	-322TSVFD	2.483	6674	0.034	0.047	0.025	0.092	6	387	361	332	277
444	227	-323VFD	2.425	6440	-323TSVFD	2.634	6994	0.028	0.041	0.025	0.083	6	440	411	382	319
535	273	-324VFD	2.643	7547	-324TSVFD	2.931	8477	0.024	0.035	0.026	0.075	6	498	443	407	340
646	326	-326VFD	2.920	8916	-326TSVFD	3.178	9888	0.020	0.030	0.026	0.068	4	553	516	474	396
777	394	-327VFD	3.102	10909	-327TSVFD	3.510	11803	0.016	0.026	0.025	0.062	4	602	562	516	431

*Cable diameters are subject to a +/- 5% manufacturing tolerance
 **3 Grounding Conductors – Green Insulated

Stranding Profile: See Page 5



Standard VFD Cable Ampacity Ratings

Based on IEEE Std. 45 with a 45°C ambient and arranged in a single bank per hanger. For those instances where cable must be double banked, the ampacities should be multiplied by 0.8.



LOW SMOKE HALOGEN-FREE VFD POWER CABLE

Three Conductor • 2kV • Rated 90°C • Gexol®-HF Insulation

Power Conductors (x3)

Soft annealed flexible stranded tinned copper per IEEE 1580 Table 11.

Insulation (2kV)

GEXOL®-HF low smoke halogen-free flame retardant cross-linked polyolefin, meeting the requirements for Type LSE or LSX of IEEE 1580.

Color: Gray with printed phase I.D.
(Black-White-Red)

Ground Conductors (x3)

Soft annealed flexible stranded tinned copper per IEEE 1580 Table 11. Gexol®-HF insulated and sized per UL 1277. Color: Green

Shield

Overall tinned copper braid plus aluminum/polyester tape providing 100% coverage.

Jacket

A black low smoke halogen-free flame retardant polyolefin, meeting IEEE 1580.

Sheath (Optional)

A black low smoke halogen-free flame retardant polyolefin, meeting IEEE 1580.

Armor (Optional)

Tinned copper basket weave wire armor per IEEE 1580.



Note: For armored versions the braid is placed between the inner jacket and outer sheath where it serves as both the EMI shield and armor.

APPLICATION

A flexible, braid and foil shielded, 2kV power cable specifically engineered for use in variable frequency AC motor drive (VFD) applications where a low smoke halogen-free insulation is required.

FEATURES

- Low Smoke and Halogen-Free.
- Specially engineered cable design produces a longer cable life in VFD applications.
- Overall braid plus foil shield is engineered with 100% coverage and a surface transfer impedance <50 milliohms at 10MHz to contain EMI.
- Symmetrical insulated ground conductors reduce induced voltage imbalances and carry common mode noise back to the drive.
- High strand count conductors and braid shield design is much more flexible and easier than IEC 60092-350 series cables to install.
- Gexol-HF's lower dielectric constant (standard HFXLPE, HFEPD insulation materials have higher dielectric constants) reduces reflected wave peak voltage magnitudes. This allows for longer output cable distances and minimizes the effect of high frequency noise induced into the plant ground system.
- 2kV insulation thickness is used to resist the potential 2-3x reflected voltages experienced in 600V VFD applications.
- Severe cold durability: exceeds CSA cold bend/cold impact (-40°C/-35°C).
- Flame retardant: IEC 332-3 Category A and IEEE 1202.
- Suitable for use in Class I, Division 1 and Zone 1 environments (armored and sheathed).
- Optional braid armor of bronze, aluminum or tinned copper.

Ratings & Approvals

- 90°C Temperature Rating
- American Bureau of Shipping (ABS)
- UL Listed as Marine Shipboard Cable: (E111461)
- Transport Canada
- Det Norske Veritas (DNV): pending
- Lloyd's Register of Shipping pending

Other certifications pending

		Unarmored			Armored & Sheathed (TS)										
Size AWG/ kcmil	mm ²	Part No. 37-103	Nominal Diameter Inches*	Weight Lbs./ 1000 Ft.	Part No. 37-103	Nominal Diameter Inches*	Weight Lbs./ 1000 Ft.	DC Resist. at 25°C Ohms/ 1000 Ft.	AC Resist. at 90°C, 60 Hz Ohms/ 1000 Ft.	Inductive Reactance Ohms/ 1000 Ft.	Voltage Drop at 90°C Volts/Amp/ 1000 Ft.	Grounding Conductor** Size (AWG)	Ampacity		
													90°C	75°C	60°C
14	2.1	-508VFD	0.674	270	-508TSVFD	0.800	381	2.907	3.635	0.040	5.073	18	24	20	15
12	3.3	-516VFD	0.696	306	-516TSVFD	0.822	431	1.826	2.283	0.038	3.199	18	29	24	18
10	5.2	-308VFD	0.776	401	-308TSVFD	0.944	561	1.153	1.441	0.036	2.032	14	38	32	23
8	7.6	-309VFD	0.832	490	-309TSVFD	1.000	672	0.708	0.885	0.037	1.263	14	48	41	29
6	12.5	-310VFD	0.912	667	-310TSVFD	1.124	921	0.445	0.556	0.033	0.804	12	65	54	39
4	21	-312VFD	1.120	954	-312TSVFD	1.288	1183	0.300	0.376	0.031	0.552	12	83	70	50
2	34	-314VFD	1.254	1290	-314TSVFD	1.422	1597	0.184	0.230	0.029	0.348	10	111	93	67
1	43	-315VFD	1.368	1592	-315TSVFD	1.595	1915	0.147	0.184	0.029	0.285	10	131	110	79
1/0	54	-316VFD	1.484	1910	-316TSVFD	1.701	2345	0.117	0.147	0.029	0.234	10	150	126	91
2/0	70	-317VFD	1.592	2306	-317TSVFD	1.819	2719	0.093	0.117	0.028	0.192	10	173	145	105
4/0	109	-319VFD	1.916	3325	-319TSVFD	2.151	3892	0.058	0.075	0.027	0.132	8	232	194	141
262	132	-320VFD	2.077	4201	-320TSVFD	2.285	4873	0.048	0.063	0.027	0.115	6	273	228	165
313	159	-321VFD	2.156	4924	-321TSVFD	2.383	5422	0.040	0.053	0.026	0.100	6	298	249	181
373	189	-322VFD	2.302	5504	-322TSVFD	2.510	6155	0.034	0.045	0.025	0.088	6	332	277	201
444	227	-323VFD	2.452	6579	-323TSVFD	2.660	7276	0.028	0.039	0.025	0.080	6	382	319	231
535	273	-324VFD	2.670	7882	-324TSVFD	3.020	9007	0.024	0.033	0.026	0.072	6	407	340	247
646	326	-326VFD	2.947	9311	-326TSVFD	3.213	10325	0.020	0.028	0.026	0.065	4	474	396	287
777	394	-327VFD	3.128	10862	-327TSVFD	3.417	12245	0.016	0.025	0.025	0.060	4	516	431	313

*Cable diameters are subject to a +/- 5% manufacturing tolerance

**3 Grounding Conductors – Green Insulated

GEXOL® is a registered trademark of AmerCable Incorporated

Strand Profile: Standard & LSHF

Size	Equivalent mm ²	IEEE 45 Std. Size	No. of Strands	Conductor O.D. (Inches)
18	0.96	2	19	0.048
16	1.32	3	19	0.056
14	2.08	4	19	0.070
12	3.30	6	19	0.088
10	5.23	10	37	0.112
8	7.57	16	37	0.134
6	12.49	26	61	0.173
4	21.11	41	133	0.257
2	33.51	66	133	0.324
1	42.79	83	209	0.363
1/0	54.45	106	266	0.401
2/0	70.01	133	323	0.451
3/0	85.57	168	418	0.505
4/0	108.91	212	532	0.567
262	132.25	262	646	0.615
313	159.06	313	777	0.704
373	189.36	373	925	0.735
444	227.23	444	1110	0.780
535	272.68	535	1332	0.871
646	325.70	646	1591	0.965
777	393.87	777	1924	1.050
1111	561.95	1111	2745	1.375

LSHF VFD Cable Ampacity Ratings

Based on IEEE Std. 45 with a 45°C ambient and arranged in a single bank per hanger. For those instances where cable must be double banked, the ampacities should be multiplied by 0.8.



CIR® TYPE VFD POWER CABLE

UL LISTED AS TYPE TC-ER & TYPE TC-ER-HL

Three Conductor • Gexol® Insulated • 600/2000V • Rated 90°C

Power Conductors (3)

Soft annealed flexible stranded tinned copper per IEEE 1580 Table 11.

Insulation (2kV)

Gexol® cross-linked flame retardant polyolefin, meeting the requirements for Type P of IEEE 1580 and Type X110 of UL 1309/CSA 245. Color: Gray with printed phase I.D. (Black-Red-Blue)

Jacket

A black, flame retardant, oil, abrasion, chemical and sunlight resistant thermoset CPE meeting UL 1309/CSA 245 and IEEE 1580.



Ground Conductors (3)

Soft annealed flexible stranded tinned copper per IEEE 1580 Table 11. Gexol® insulation sized per UL 1277. Color: Green
Note: Sizes over 1" OD have uninsulated grounds

Shield

Overall tinned copper braid plus aluminum/polyester tape providing 100% coverage.

Safer to Handle

CIR® has no sharp metal armor edges that imperil worker's hands during splicing and installation of connectors



Ratings & Approvals

- 90°C temperature rating
- UL Listed as TC-ER-HL – suitable for Class 1, Div 1 and Zone 1 environments
- UL Listed as Type TC-ER – Suitable for use in Class I, Div 2 and Zone 2 environments
- American Bureau of Shipping (ABS) (99-BT5905-X)
- UL Listed as Marine Shipboard Cable (E111461)
- Flame Retardant – IEEE 1202
- Suitable for use in Class I, Div 2 and Zone 2 environments

APPLICATION

A flexible braid and foil shielded power cable specifically engineered for use in variable frequency AC motor drive (VFD) applications where user requires crush and impact protection.

FEATURES

- Specially engineered cable design produces longer service life in VFD applications.
- Overall braid and foil shield provides 100% coverage containing VFD EMI emissions.
- Symmetrical insulated ground conductors reduce induced voltage imbalances and carry common mode noise back to the drive.
- High strand count conductors and braid shield design is much more flexible, easier to install and more resistant to vibration than Type MC.
- GEXOL's lower dielectric constant (standard XLPEs, EPRs and other Type P insulation materials have higher dielectric constants) reduces reflected wave peak voltage magnitudes. This allows for longer output cable distances and minimizes the effect of high frequency noise induced into the plant ground system.
- 2kV insulation thickness resists the repetitive 2x voltage spikes from 600V VFDs and reduces drive over current trip problems due to cable charging current.
- Passes the same stringent crush and impact testing required by UL 2225 for Type MC-HL
- Gas & vapor tight – impervious to water and air

CIR vs. TYPE MC

- Smaller bend radius (up to 40% smaller)
- Reduced tray fill (up to 35% less)
- Considerably more flexible
- Reduced installation time and cost
- Glands cost up to 50% LESS

CIR® TYPE VFD POWER CABLE

Size AWG/ kcmil	Part No. 37-102-	Nominal Diameter Inches	Weight Per 1000 Ft.	DC Resist. @ 25°C (Ohms/1k ft)	AC Resist. @ 90°C, 60 Hz (Ohms/1k ft)	Inductive Reactance (Ohms/1k ft)	Voltage Drop @ 90°C (Volts/Amp/1k ft)	Green Insulated Grounding Size (AWG)	IEEE Ampacity 90°C	NEC Ampacity 90°C	IEEE Ampacity 75°C	NEC Ampacity 75°C
14	508CIRVFDA	0.742	283	2.907	3.635	0.040	5.073	18	24	15	20	15
12	516CIRVFDA	0.815	378	1.826	2.283	0.038	3.199	18	29	20	24	20
10	308CIRVFDA	0.871	473	1.153	1.441	0.036	2.032	14	38	30	32	30
8	309CIRVFDA	0.893	553	0.708	0.885	0.037	1.263	14	48	55	41	50
6	310CIRVFDA	1.093	797	0.445	0.556	0.033	0.804	12	65	75	54	65
4	312CIRVFDA	1.225	929	0.300	0.376	0.031	0.552	12	83	95	70	85
2	314CIRVFDA	1.341	1276	0.184	0.230	0.029	0.348	10	111	130	93	115
1	315CIRVFDA	1.447	1576	0.147	0.184	0.029	0.285	10	131	145	110	130
1/0	316CIRVFDA	1.566	2144	0.117	0.147	0.029	0.234	10	150	170	126	150
2/0	317CIRVFDA	1.733	2144	0.093	0.117	0.028	0.192	10	173	195	145	175
4/0	319CIRVFDA	1.874	3131	0.058	0.075	0.027	0.132	8	232	260	194	230
262	320CIRVFDA	2.031	3875	0.048	0.063	0.027	0.115	6	273	297	228	262
313	321CIRVFDA	2.130	4709	0.040	0.053	0.026	0.100	6	298	328	249	292
373	322CIRVFDA	2.257	5209	0.034	0.045	0.025	0.088	6	332	364	277	322
444	323CIRVFDA	2.400	6310	0.028	0.039	0.025	0.080	6	382	402	319	355
535	324CIRVFDA	2.705	7193	0.024	0.033	0.026	0.072	6	407	446	340	394
646	326CIRVFDA	2.898	9217	0.020	0.028	0.026	0.065	4	474	496	396	438
777	327CIRVFDA	3.102	10340	0.016	0.025	0.025	0.060	4	516	546	431	483

NOTE: Cable diameters are subject to a +/- 5% manufacturing tolerance

Ampacities are based on Table 310.15 (B) (16) of the National Electrical Code (NEC) for conductors rated 90°C, in a multi-conductor cable, at an ambient temperature of 30°C. The 75°C column is provided for additional information. The ampacities shown apply to open runs of cable, installation in any approved raceway. Derating for more than three current carrying conductors within the cable is in accordance with NEC Table 310.15 (B) (3) (a). The ampacities shown also apply to cables installed in cable tray in accordance with NEC Section 392.80.



Gexol® and CIR® are registered trademarks of AmerCable Incorporated

37-105VFD

MMV-VFD POWER CABLE

Three Conductor: 8kV – 15kV • 133% Insulation Level • Rated 90°C

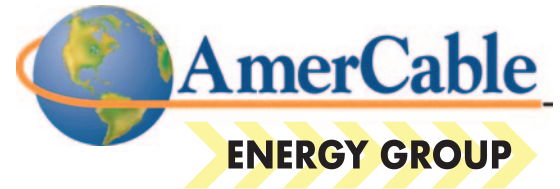

Conductors (3)

Soft annealed flexible stranded finned copper per IEEE 1580 Table 11.

Insulation

Extruded thermosetting 90°C Ethylene Propylene Rubber (EPR), meeting UL 1309 (Type E), IEEE 1580 (Type E) and UL 1072.

Insulation Shield

Composite shield consisting of 0.0126" finned copper braided with nylon providing 60% copper shielded coverage meeting UL 1309, IEEE Std. 1580, and UL 1072. The nylon is colored for easy phase identification (three conductor = black, blue, red) without the need to remove the shield to find an underlying colored tape.

Low smoke halogen-free jacket available on request.

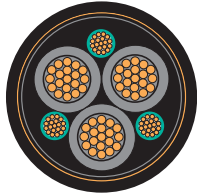

Conductor Shield

A combination of semi-conducting tape and extruded thermosetting semi-conducting material meeting UL 1309, IEEE 1580 and UL1072.

Insulation Shield

Semi-conducting layer meeting UL 1309, IEEE 1580 and UL 1072.

Symmetrical Insulated Grounding Conductors (3)

Soft annealed flexible stranded tinned copper conductor per IEEE 1580 Table 11. Gexol Insulation sized per Table 23.2 of UL1072. Color: Green

Jacket

A black, arctic grade, flame retardant, oil, abrasion, chemical and sunlight resistant thermosetting compound meeting UL 1309/ CSA 245, IEEE 1580, and UL 1072. This jacket allows for isolation between the insulation shields and overall shield. Shields can then be terminated on opposite ends to minimize circulating currents.

Armor/EMI Shield

Overall tinned copper braid plus aluminum/polyester tape provides 100% coverage. This braid serves as both an armor and EMI shield meeting both IEEE 1580 and UL 1307/CSA 245.

Sheath (optional)

A black, arctic grade, flame retardant, oil, abrasion, chemical and sunlight resistant thermosetting compound meeting UL 1309/CSA 245, IEEE 1580, and UL 1072. Colored jackets for signifying different voltage levels are also available on special request (orange = 8kV and red = 15kV).

APPLICATIONS

A flexible, braid and foil shielded, power cable specifically engineered for use in medium voltage variable frequency AC drive (VFD) applications.

FEATURES

- Flexible stranded conductors and braided shields. Suitable for applications involving repeated flexing and high vibration.
- Small minimum bending radius (8x OD) for easy installation.
- Insulation has a very low dielectric constant. This allows for longer output cable distances and minimizes common mode current.
- Overall braid plus foil shield is engineered with 100% coverage and a surface transfer impedance <50 milliohms at 10MHz to contain EMI.
- Symmetrical insulated ground conductors reduce induced voltage imbalances and carry common mode noise back to the drive.
- High strand count conductors and braid shield design is much more flexible, easier to install and more resistant to vibration than Type MC cable.
- Severe cold durability: exceeds CSA cold bend/cold impact (-40°C/-35°C).
- Flame retardant: IEC 332-3 Category A and IEEE 1202.
- Suitable for use in Class I, Division 1, and Zone 1 environments.

Ratings & Approvals

- UL Listed as Marine Shipboard Cable (E111461)
- American Bureau of Shipping (ABS)
- Det Norske Veritas (DNV) Pending
- Lloyd's Register of Shipping (LRS) Pending
- 90°C Temperature Rating
- Voltage Rating – 8kV to 15kV (25kV available on request)

THREE CONDUCTOR TYPE MMV-VFD MARINE MEDIUM VOLTAGE 8KV • 133% INSULATION LEVEL

		Ampacity										
Size AWG/ kcmil	mm ²	Part No. 37-105	Nominal Diameter (Inches)	Weight (Lbs./ 1000 Ft.)	In Free Air (Amps)	Single Banked in Trays (Amps)	DC Resistance at 25°C (Ohms/1000 Ft.)	AC Resistance at 90°C, 60Hz (Ohms/1000 Ft.)	Inductive Reactance (Ohms/ 1000 Ft.)	Voltage Drop (Volts/Amp/ 1000 Ft.)	Green Insulated Grounding Conductor (3x) Size (AWG)	
6	12.5	-332TSVFD	1.687	1634	88	75	0.445	0.556	0.048	0.820	10	
4	21	-333TSVFD	1.868	2074	116	99	0.300	0.376	0.043	0.564	10	
2	34	-334TSVFD	2.071	2625	152	129	0.184	0.230	0.040	0.359	10	
1	43	-335TSVFD	2.161	3022	175	149	0.147	0.184	0.038	0.294	8	
1/0	54	-336TSVFD	2.262	3373	201	171	0.117	0.147	0.037	0.242	8	
2/0	70	-337TSVFD	2.381	3826	232	197	0.093	0.117	0.036	0.199	8	
3/0	86	-338TSVFD	2.489	4411	266	226	0.074	0.094	0.035	0.166	6	
4/0	109	-339TSVFD	2.631	5093	306	260	0.058	0.075	0.033	0.139	6	
262	132	-340TSVFD	3.857	5993	348	296	0.048	0.063	0.032	0.121	6	
313	159	-341TSVFD	3.030	6867	386	328	0.040	0.053	0.032	0.106	6	
373	189	-342TSVFD	3.164	7810	429	365	0.034	0.045	0.031	0.094	4	
444	227	-343TSVFD	3.319	8855	455	387	0.028	0.039	0.030	0.085	4	
535	273	-344TSVFD	3.492	9905	528	449	0.024	0.033	0.030	0.076	4	

THREE CONDUCTOR TYPE MMV-VFD MARINE MEDIUM VOLTAGE 15KV • 133% INSULATION LEVEL

		Ampacity										
Size AWG/ kcmil	mm ²	Part No. 37-105	Nominal Diameter (Inches)	Weight (Lbs./ 1000 Ft.)	In Free Air (Amps)	Single Banked in Trays (Amps)	DC Resistance at 25°C (Ohms/1000 Ft.)	AC Resistance at 90°C, 60Hz (Ohms/1000 Ft.)	Inductive Reactance (Ohms/ 1000 Ft.)	Voltage Drop (Volts/Amp/ 1000 Ft.)	Green Insulated Grounding Conductor (3x) Size (AWG)	
2	34	-357TSVFD	2.403	3231	156	133	0.184	0.230	0.0440	0.364	10	
1	43	-358TSVFD	2.468	2959	178	151	0.147	0.184	0.0430	0.299	8	
1/0	54	-359TSVFD	2.596	4090	205	174	0.117	0.147	0.041	0.246	8	
2/0	70	-360TSVFD	2.714	4615	234	199	0.093	0.117	0.0390	0.203	8	
3/0	86	-361TSVFD	2.875	5306	269	229	0.074	0.094	0.038	0.170	6	
4/0	109	-362TSVFD	3.028	6131	309	263	0.058	0.075	0.037	0.142	6	
262	132	-363TSVFD	3.260	7074	352	299	0.048	0.063	0.035	0.124	6	
313	159	-364TSVFD	3.363	7787	389	331	0.040	0.053	0.034	0.109	6	
373	189	-365TSVFD	3.500	8703	432	367	0.034	0.045	0.034	0.097	4	
444	227	-366TSVFD	3.652	9912	456	388	0.028	0.039	0.033	0.080	4	

MMV-VFD
Stranding Profile:
See Page 10

Ordering Type MMV-VFD Medium Voltage
Cables

Example:

- 3 conductor MMV-VFD power cable
- 15kV
- #2 AWG

37-105 - 357TSVFD

AmerCable Type
MMV-VFD Prefix

Specific Cable Number
(from charts)

MMV-VFD Power Cable

MMV-VFD Stranding Profile				
Size AWG/kcmil	Number of Strands	Closest IEEE 45 Std. Size	Equivalent Metric Size (mm ²)	Uninsulated Conductor Dia. (inches)
6	61	26	12.49	0.175
4	133	41	21.11	0.258
2	133	66	33.51	0.324
1	209	83	42.79	0.361
1/0	266	106	54.45	0.407
2/0	342	133	70.01	0.461
3/0	418	168	85.57	0.510
4/0	532	212	108.91	0.575
262	646	262	132.25	0.654
313	777	313	159.06	0.720
373	925	373	189.36	0.785
444	1110	444	227.23	0.860
535	1332	535	272.68	0.941

Hawke Gland Types	
Industrial & Safe Area (IP68)	153-X
Increased Safety	501/453/U
Explosion Proof	753 Class I, Div. 1 Class I, Zone 1 & 2
Flameproof "EExd"	501/453/U (2 liter or < enclosures) ICG 653/U (2 liter or > enclosures) Zone 1 & 2

MMV-VFD Bend Radius	
IEEE 45	8X Diameter
IEC 60092-352	9X Diameter

MMV-VFD Ampacities & Electrical Data

Ampacities are based on API RP 14F (July 2008) Table 3 for multi-conductor cables. The notes to these tables are also applicable. Ampacities are also based on a 90°C conductor temperature and a 45°C ambient temperature.

Inductive reactance and voltage drop values are based on a 90°C conductor temperature and 60 Hz operation.

Cable Selection Guide for VFD Applications

The circuit of a typical voltage source PWM drive is shown in Figure 1. Each part of the equipment is bonded to the safety earth system to ensure personnel safety if faults occur.

All parts have capacitance to ground shown by:

- CM for the motor windings.
- CC1 and CC2 for the power converter circuits.
- CT for the transformer's secondary winding to the transformers' screen.

The IGBT switches are in constant operation at high frequency and this produces an inverter output voltage with a PWM wave shape as shown by the voltage V1 (Figure 1).

This IGBT switches also cause a motor line to ground voltage V2 (Figure 1), normally called a common mode voltage.

The common mode voltages cause short high-frequency pulses of common mode current to flow in the safety earth circuits, shown by currents I1 and I2 (Figure 1), unless the design includes cable features to stop this from happening.

It is essential that the common mode currents return to the inverter without causing EMC - EMI problems in other equipment, and this means that the common mode currents I1 and I2 must not flow in the safety earthing system.

For the motor, this is achieved by connecting a set of wires from the motor to the inverter that run with the main power cables. These are called symmetrical insulated grounding conductors, see Figure 2. These conductors have a very low impedance compared with the other return path via the safety earthing system.

The three symmetrical insulated grounding conductors and overall shields are connected as shown in Figure 3. This 360° connection is essential.

The common mode currents I1 and I2 now flow in the symmetrical insulated grounding conductors. This happens because the symmetrical insulated grounding conductors are close to the power conductors giving a low impedance route for the currents I1 and I2 compared with the safety earthing system.

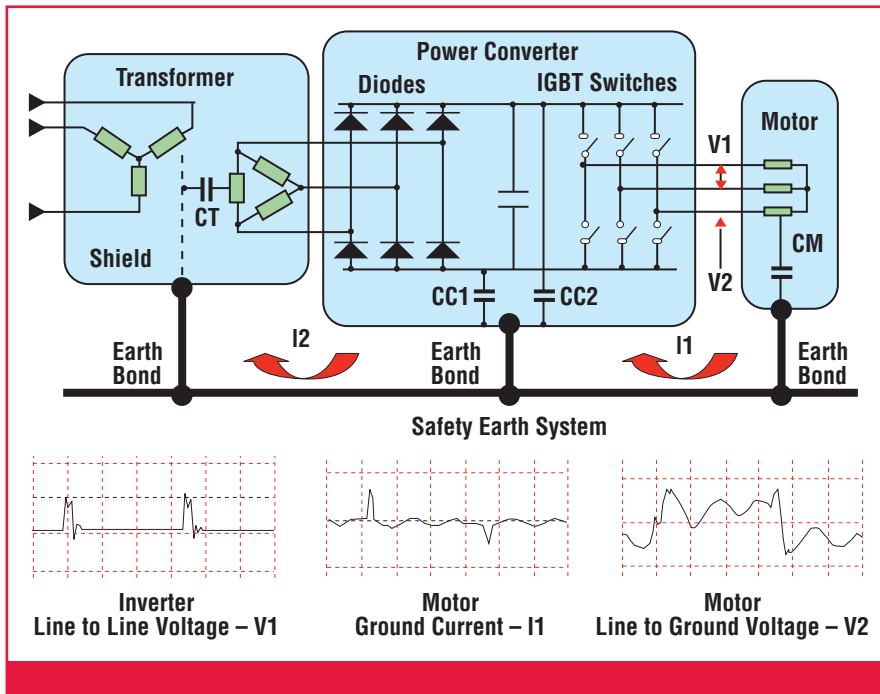

The essential features of a medium voltage cable for PWM drives are:

- Insulation designed to withstand the transients produced by the PWM
- Insulation with a dielectric constant no greater than 3.0 to minimize capacitance
- Voltage rating of 3x the operating voltage to prevent corona
- Three symmetrical insulated grounding conductors. Some cables only have one grounding conductor. This is not acceptable as it produces circulating currents in the earth system
- Extremely fine strands to carry the harmonic currents without overheating (i.e. the inductance of fine stranded conductors is less than 7, 19, 37 strand conductors)
- Overall shield to stop the radiation of voltage EMI fields
- Correct termination at both ends
- Semi-conducting shield around each insulation layer
- Metallic layer around each semi-conducting shield to earth the semi-conducting shield

As I_1 and I_2 flow near the power conductors this avoids creating external EMC - EMI problems.

If symmetrical insulated grounding conductors and an overall EMI shield are not used, EMC - EMI problems are very likely to occur.

For cables used with voltage source PWM drives, a number of features are required to ensure correct operation, avoid overheating and achieve longer service life.

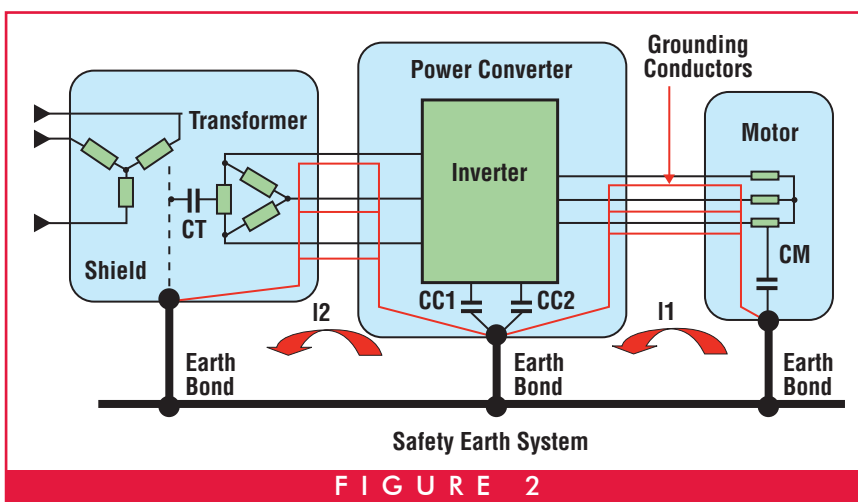

FIGURE 2

Figures 1 - 3 courtesy of Convertteam

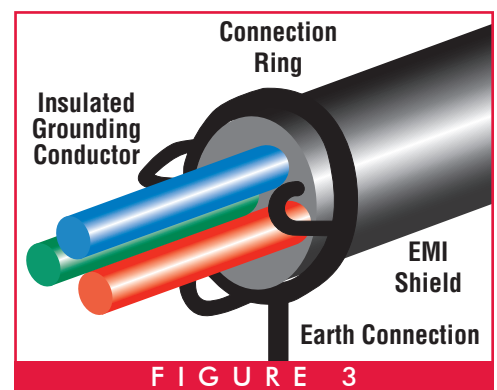

FIGURE 3

VFD CABLES

AmerCable is an ISO 9001:2015 certified cable manufacturer that combines leading-edge manufacturing technology, innovative thinking, and high quality service to deliver the finest, most flexible VFD cable products available.



AmerCable's professional field engineers and sales force work with you to create innovative, cost effective project solutions.



WHAT CAN YOU EXPECT FROM AMERCABLE?

- Shortest Lead Times in the Industry
- Best at On-Time Delivery
- Professional Sales, Support and Service
- Global Cable Management



Made in America

FOLLOW US!

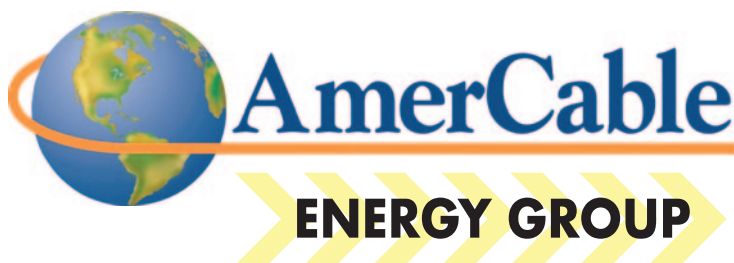

AmerCable

350 Bailey Road • El Dorado, Arkansas USA
(870) 862-4919 • (800) 643-1516

Fax (870) 862-9613

e-mail: mining.sales@nexans.com

www.AmerCable.com